

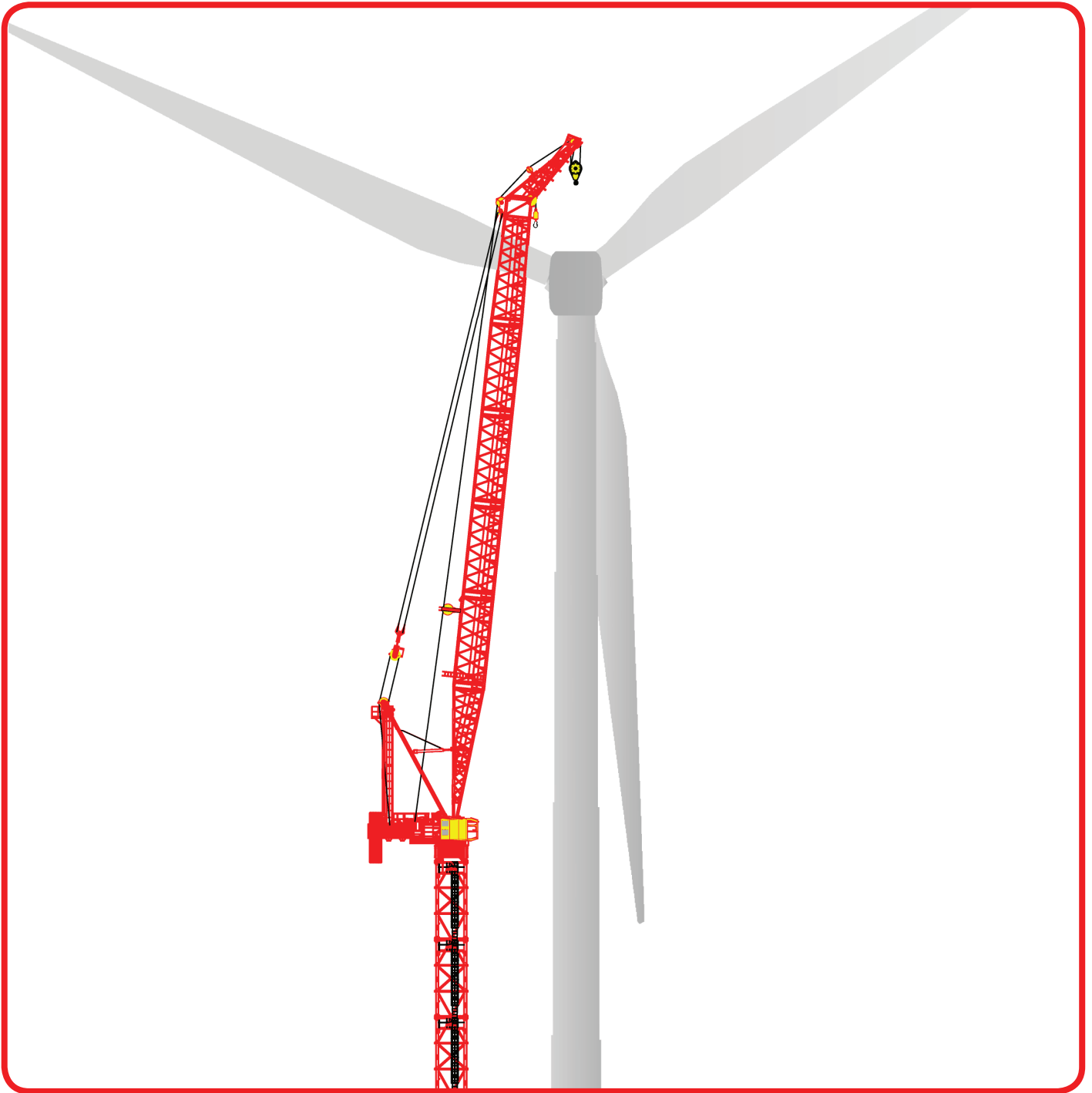

**KRØLL CRANES**



F.E.M 1.001-HC1/A3/E3



**LUFFING BOOM  
TOWER CRANE**

**K1650L**

**135 tonnes Max**

# ERECTED DIMENSIONS

Lifts above 60 tonnes are limited to 15 m/s wind speed

## FORCES AT GROUND LEVEL

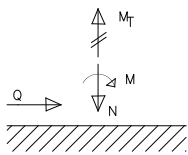





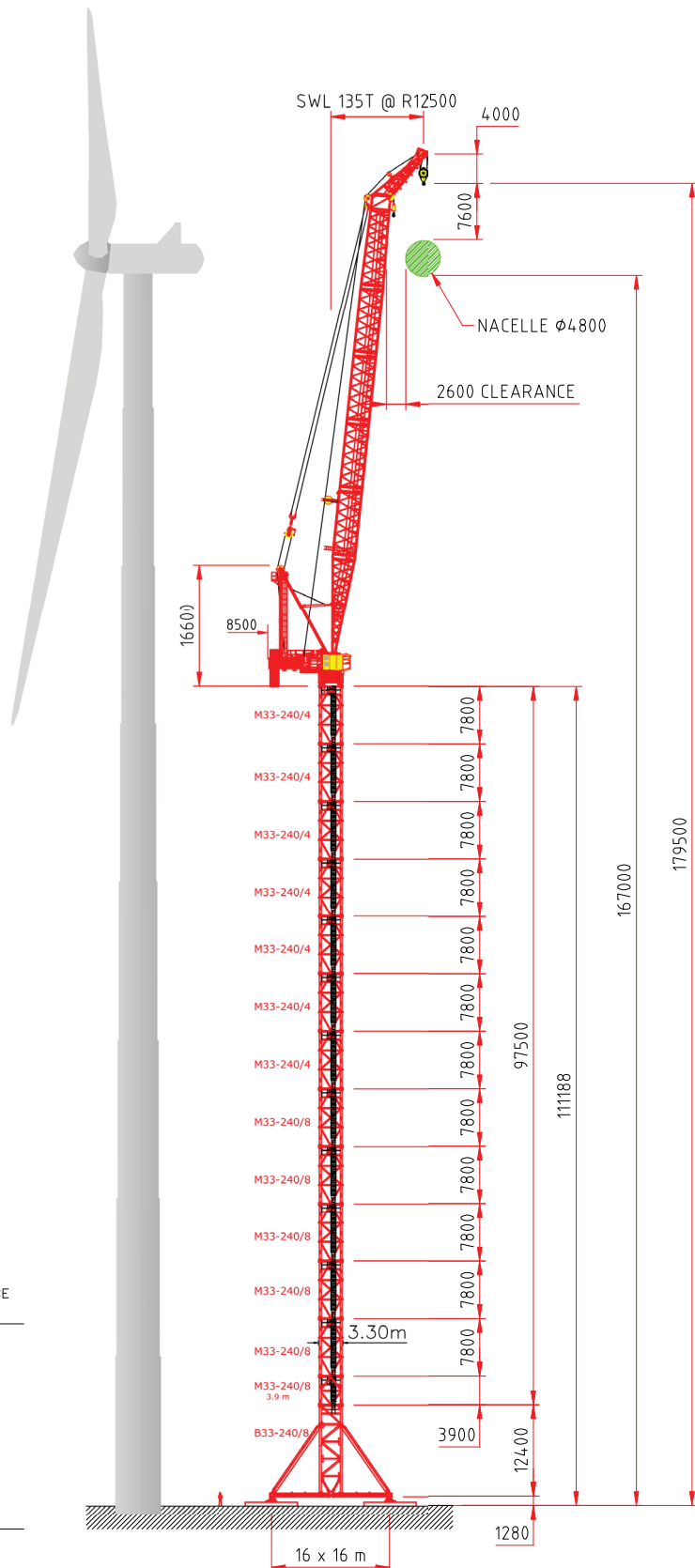

### BASE FORCES, 167.0 m (111.2 m mast)

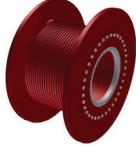
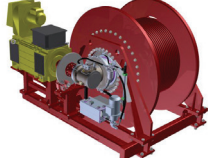
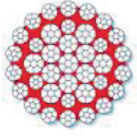
Wind speed	IN SERVICE	OUT OF SERVICE
	15 m/s	40 m/s
M (kNm)	31000	28000
N (kN)	7200	5700
Q (kN)	130	430
M <sub>T</sub> (kNm)	800	0
Deflection, masth. (m)	1.700	0.900
Tilt, masth. (degrees)	1.300	0.500
Corner load (kN) 16x16m BX	3100	2600

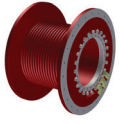
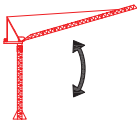

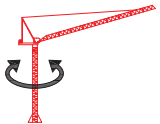
Radius	Boom Length	
	69.0 m	
	Boom Angle	4 parts
[m]	[Degrees]	[Kg]
9.0	87.0	135,000
10.0	86.2	135,000
12.5	84.1	135,000
15.0	82.0	108,800
17.5	79.9	89,100
20.0	77.7	74,300
22.5	75.5	62,800
25.0	73.4	53,600
27.5	71.1	46,100
30.0	68.9	39,800
32.5	66.6	34,500
35.0	64.2	30,000
37.5	61.8	26,100
40.0	59.3	22,700
42.5	56.7	19,700
45.0	54.1	17,100
47.5	51.3	14,700
50.0	48.4	12,600
52.5	45.4	10,700
55.0	42.2	9,000
57.5	38.7	7,400
60.0	34.8	5,900
62.5	30.5	4,600
65.0	25.4	3,400
67.5	18.6	2,400
68.5	15.0	2,000

<b>HOIST WINCH</b>  <b>MOTOR</b> 154 kW	<b>4-PARTS</b> 			<b>HOIST DRUM</b>  <b>CAPACITY</b> 720 m / 7 layers										
		Load 0 - 10 t 10 - 60 t 60 - 135 t		Max. Speed 21 m/min 11 m/min 6 m/min		<b>HOIST WIRE</b> <table border="1"> <tr> <td><b>Diameter</b></td> <td>40 mm</td> </tr> <tr> <td><b>Safety Factor</b></td> <td>4.6</td> </tr> <tr> <td><b>MBL</b></td> <td>1560 kN</td> </tr> </table>		<b>Diameter</b>	40 mm	<b>Safety Factor</b>	4.6	<b>MBL</b>	1560 kN	
<b>Diameter</b>	40 mm													
<b>Safety Factor</b>	4.6													
<b>MBL</b>	1560 kN													
	<b>LUFFING WINCH</b>  <b>MOTOR</b> 90 kW			<b>LUFFING DRUM</b>  <b>CAPACITY</b> 242 m / 5 Layer										
<b>LUFFING SPEEDS</b> 			<b>LUFFING WIRE</b> <table border="1"> <tr> <td><b>Diameter</b></td> <td colspan="2">32 mm</td> </tr> <tr> <td><b>Safety Factor</b></td> <td colspan="2">4.7</td> </tr> <tr> <td><b>MBL</b></td> <td colspan="2">930 kN</td> </tr> </table>			<b>Diameter</b>	32 mm		<b>Safety Factor</b>	4.7		<b>MBL</b>	930 kN	
<b>Diameter</b>	32 mm													
<b>Safety Factor</b>	4.7													
<b>MBL</b>	930 kN													
Average	4:00 min													
<b>AUXILIARY WINCH</b>  <b>MOTOR</b> 85 kW	<b>1-PART</b> 			<b>SLEW DRIVE</b>  <b>Motor</b> 2 x 11 kW										
	Load 0 - 2 t 2 - 6 t 6 - 16 t	Max. Speed 100 m/min 60 m/min 28 m/min		<b>SLEW SPEEDS</b> 										
9 - 68.5 m	0 - 0.5 rpm													
	<b>POWER</b>  <b>SUPPLY</b> 400 - 480 V, 50/60 Hz			<b>SUPPLY CABLE</b>										
	<b>Consumption</b>	320 kVA		<b>Cable Length</b>	<b>Cable Type</b>									
	<b>Main Fuse</b>	400 A		<b>0 - 120 m</b>	4 x 185 mm <sup>2</sup>									
	<b>Recommended Generator Size</b>	400 kVA												

All motion controls are completely stepless ensuring smooth and jerk-free operation.  
Creeping speed down to 0.5% of maximum speed.

All specifications shown in the tables are for the standard version of K1500L. For special requirements regarding load charts or drive speeds, please contact Krøll Cranes A/S.

# WEIGHTS & DIMENSIONS

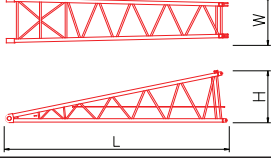
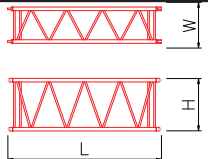
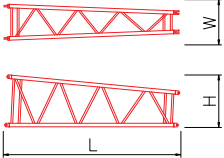
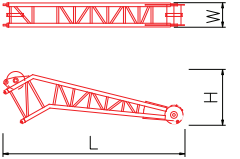
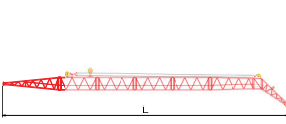
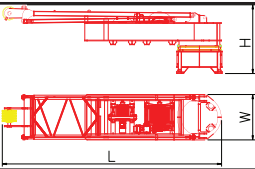
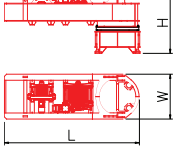
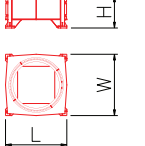
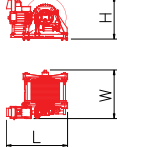
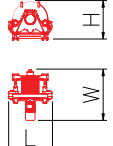
Component	Weight	Transportation Dimensions		
		Length	Width	Height
 <p>Boom Bottom Section</p>	6,500 kg	14.3 m	3.2 m	3.3 m
 <p>Boom Extension Section - 4 pcs</p>	4,000 kg	9.4 m	2.8 m	3.2 m
 <p>Boom Top Section</p>	5,000 kg	11.0 m	2.8 m	3.25 m
 <p>Boom Tip Section</p>	5,000 kg	10.75 m	1.45 m	3.3 m
 <p>Boom Assembly c/w Pendants</p>	32,500 kg	70.1 m		
 <p>Assembly Option 1 Deck, Slew Mount, Mast and Winches</p>	90,000 kg	14.7 m	3.3 m	5.0 m
 <p>Assembly Option 2 Deck, Slew Mount and Winches</p>	75,000 kg	9.95 m	3.3 m	4.5 m
 <p>Slew Mount</p>	9,500 kg	3.3 m	3.3 m	1.72 m
 <p>Hoist Winch + 800m Hoist Rope Total</p>	11,500 kg 6,400 kg 17,900 kg	3.97 m	3.15 m	2.76 m
 <p>Luffing Winch + 200m Luffing Rope Total</p>	5,000 kg 1,000 kg 6,000 kg	2.4 m	2.05 m	1.8 m

# WEIGHTS & DIMENSIONS

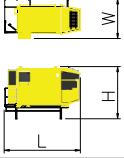
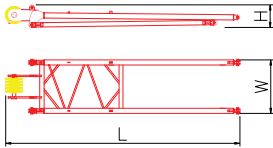
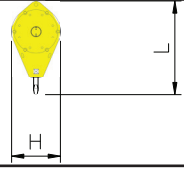
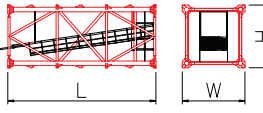
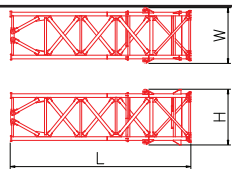
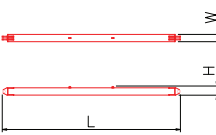
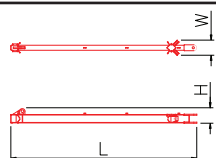
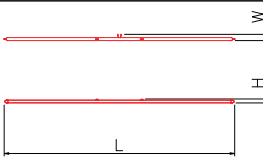
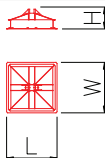
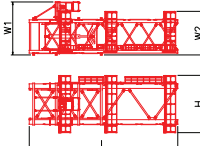
Component	Weight	Transportation Dimensions		
		Length	Width	Height
 <p>Operator's Cabin Assembly</p>	3,100 kg	4.6 m	2.395 m	3.15 m
 <p>Mast Assembly incl. access ladder &amp; platform</p>	13,500 kg	15.0 m	3.4 m	3.4 m
 <p>Hook Block</p>	3,500 kg	2.4 m	1.25 m	0.7 m
 <p>M33 Tower Assembly</p>	15,000 kg	7.8 m	3.3 m	3.3 m
 <p>B33 Bottom Mast</p>	22,000 kg	11.9 m	3.67 m	3.67 m
 <p>B33 Support Legs - 4 pcs</p>	3,000 kg	12.43 m	0.508 m	0.630 m
 <p>Bottom Cross Beams - 4 pcs</p>	3,000 kg	11.07 m	0.9 m	0.9 m
 <p>Bottom Cross Side Beams - 2 pcs</p>	700 kg	15.41 m	0.415 m	0.19 m
 <p>Pyramid Base - 4 pcs</p>	3,000 kg	2.3 m	2.3 m	1.0 m
 <p>CT33 Climbing System</p>	33,000 kg	16.15 m	W1 = 5.76 m W2 = 4.74 m	6.23 m

# WEIGHTS & DIMENSIONS

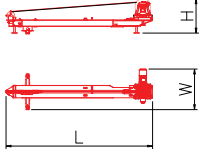
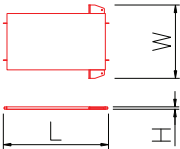
Component		Transportation Dimensions			
		Weight	Length	Width	Height
	Erection Beam & Winch	6,000 kg	9.1 m	2.32 m	2.2 m
	Counterweight - 11 pcs	9,100 kg	5.04 m	3.06 m	0.1 m

## NOTES

# ERECTION SEQUENCE

1

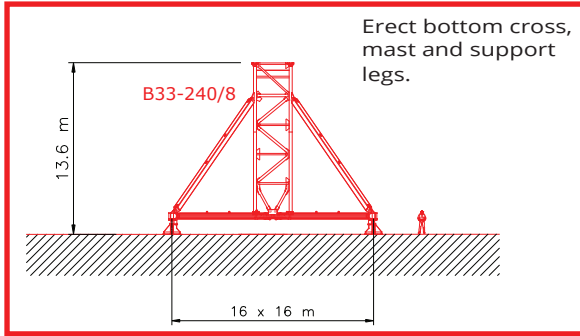

2

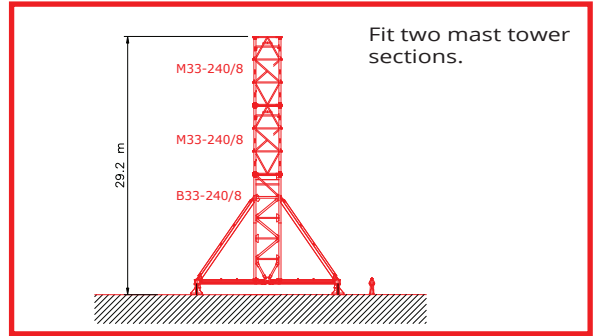

3

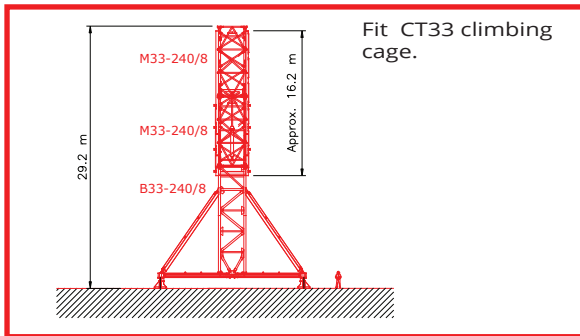

4

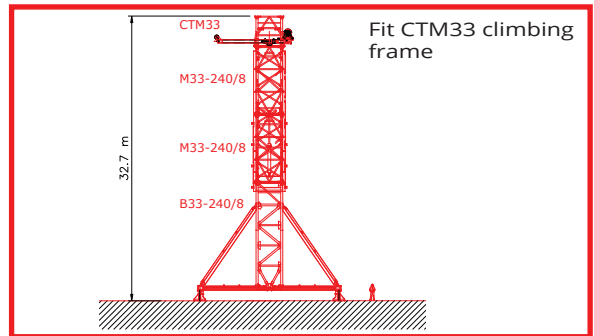

5

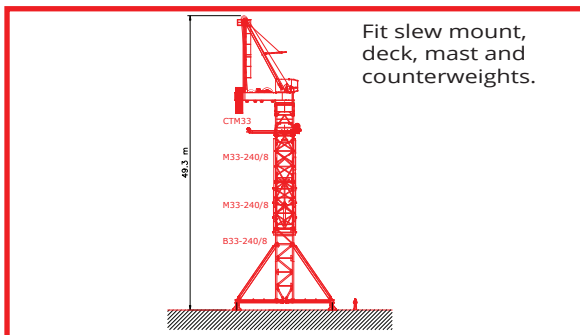

6

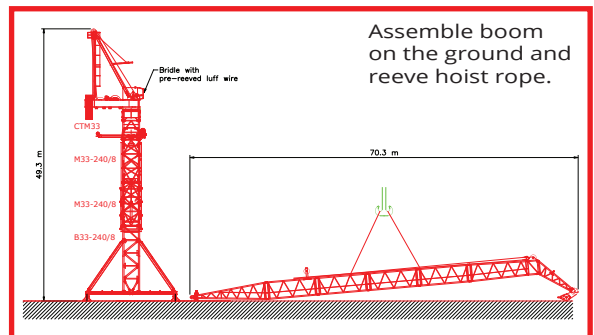

7

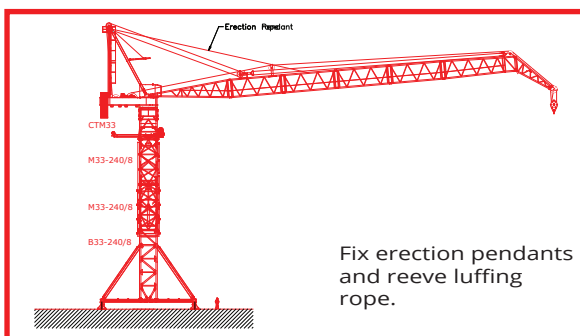

8

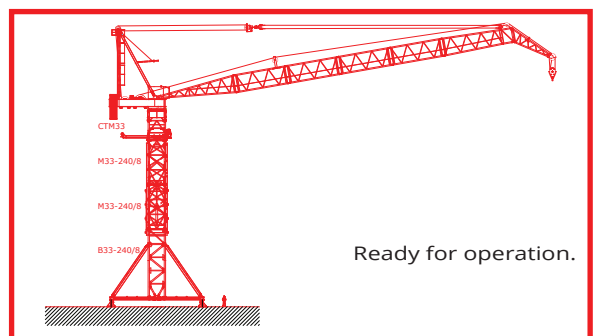

9

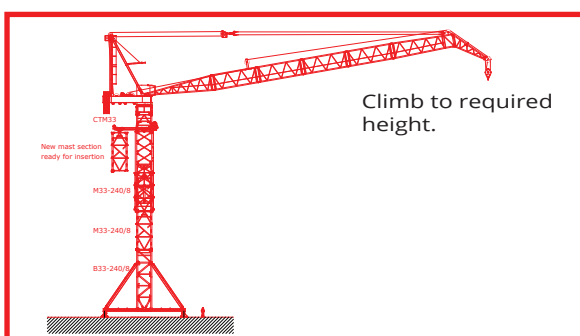

10

